



A Tsurumi Pump Company

Data sheet

CTG 300/4/80 A0ET5



GREY
series

Technical specification

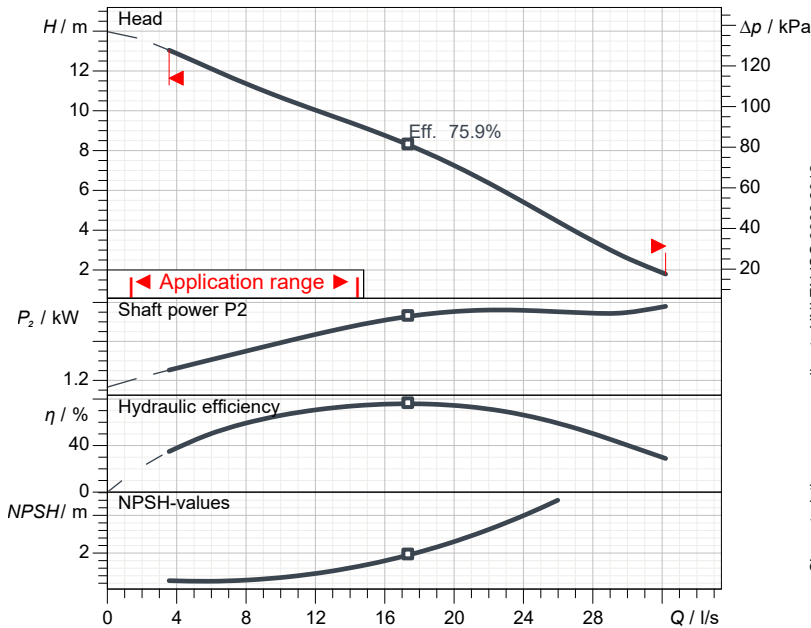

Characteristic curves according to UNI EN ISO 9906:2012
P2 < 10kW: paragraph 4.4.2
10kW < P2 < 100kW: Grade 3B
P2 > 100kW: Grade 2B

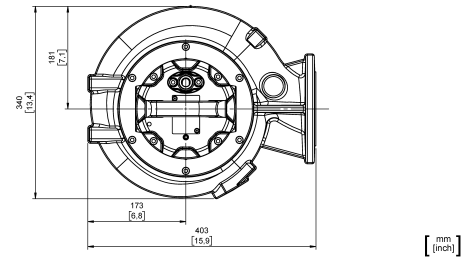
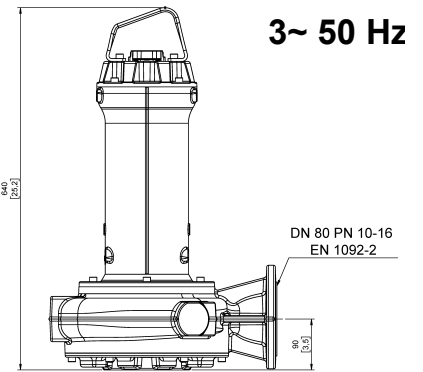

Pump

Series	GREY series
Type	CTG 300/4/80 A0ET5
Version	TS 10 400D EX NN GS
ATEX mark	II 2G Ex db h IIB T4 Gb
ATEX Certificate No.:	EPT 19 ATEX 3283 X
IECEX mark	Ex db h IIB T4 Gb
IECEX Certificate No.:	IECEX EUT 20.0008X

Operating limits (standard pumps)

Max. ambient temperature	40 °C
Max. density treated liquid	1100 kg/m ³
pH treated liquid	6 ÷ 14
Max. start per hour (equally distributed)	20
Wet/dry use	WET
Max. acoustic pressure level	70 dB
Operating mode*	Continuous use - S1 Discontinuous use (excluding FM models) S3 = 20%

*check the minimum operating level on dimensional drawing page

Motor data

Rated voltage	400 V
Frequency	50 Hz
Motor phases	3~
Number of poles	4
Rated power P2	2.20 kW
Incoming power P1	2.75 kW
Rated current	5.2 A
rpm	1410 1/min
Efficiency	79.9 %
cos φ	0.770
Rated torque	14.9 Nm
Start	Direct starting
Starting current	25.3 A
Starting torque	31.4 Nm
Degree of protection	IP 68
Insulation class	H
Run capacitor (CR)*	-
Startup capacitor (CS)*	-

* CR and/or CS included, with connections to be made in the electrical panel

Construction materials

Case	Cast iron EN-GJL 250
Shaft	Stainless steel AISI 431
Hydraulic	Cast iron EN-GJL 250
Impeller	Cast iron - EN-GJS 600
Painting/Coating	Bi-epoxy 200 μm sea water resistant
Screws	Stainless steel - Class A2-70
Gaskets	NBR

Construction features

Cooling system	-
Main cable	4G1,5 + 3x1
Cable length	10 mt
Mechanical seals	2 in silicon carbide (2SiC)
Additional drilling	-
Weight*	125.4 kg
Electrical variant	Thermal protection and leakage sensor

* cable and fixing system excluded

Hydraulic

Free passage	32 mm
Impeller type	Open channel impeller with cutting system
Max. hydraulic efficiency	75.9 %
Suction	DN 100 UNDRILLED
Discharge	DN 80 EN 1092-2



A Tsurumi Pump Company

Data sheet CTG 300/4/80 A0ET5



GREY
series

Pump performance curves

3~ 50 Hz

Impeller type Open channel impeller with cutting system		Free passage 32 mm	Discharge DN 80	Suction DN 100	
DUTY POINT					
Flow	Head	Shaft power P2	Hydraulic efficiency	Density 998.3 kg/m ³	Viscosity 1.005 mm ² /s

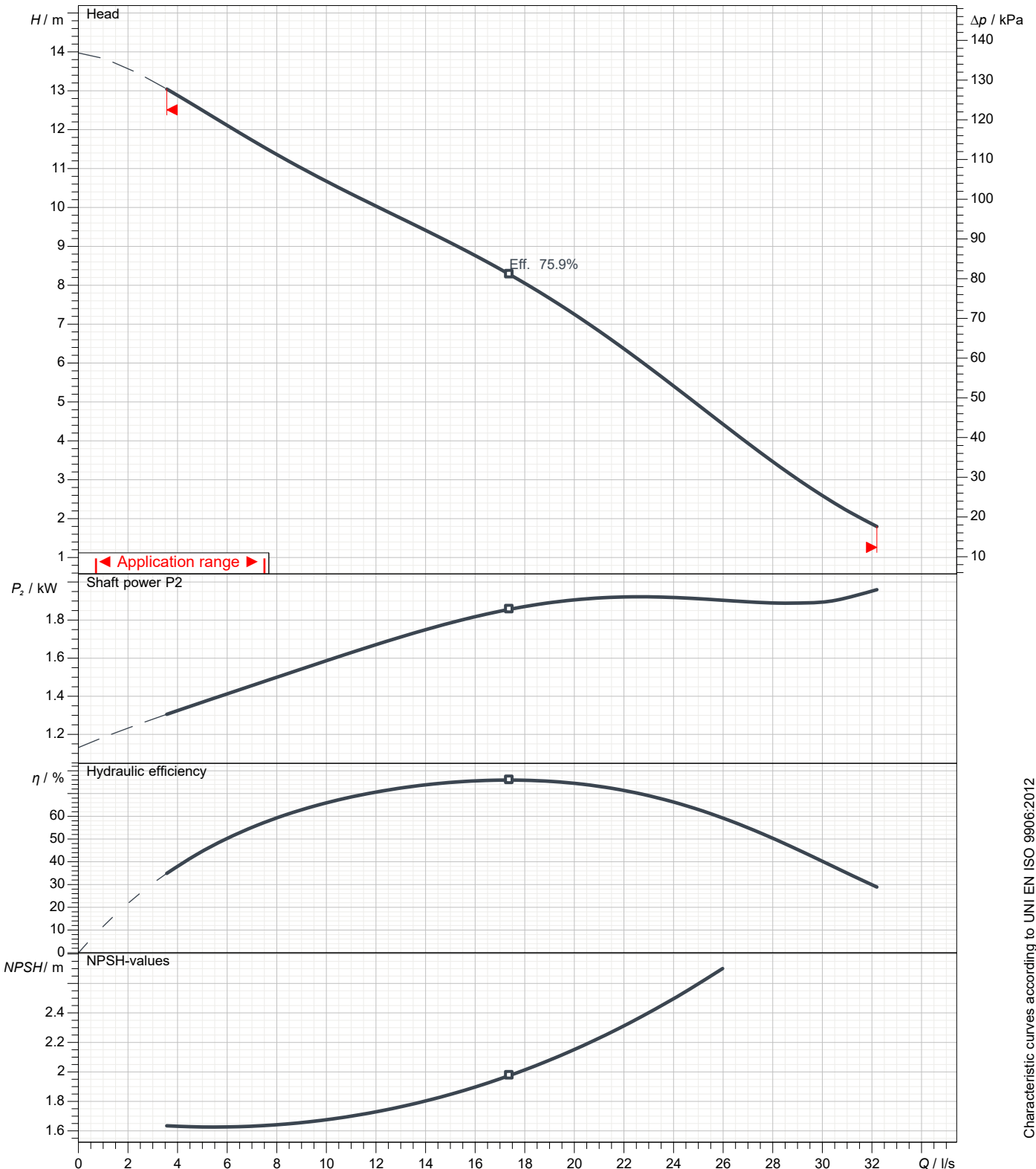

Characteristic curves according to UNI EN ISO 9906:2012
P2<10kW: paragraph 4.4.2
10kW<P2<100kW: Grade 3B
P2>100kW: Grade 2B



A Tsurumi Pump Company

Data sheet CTG 300/4/80 A0ET5



GREY
series

Dimensional drawing

3~ 50 Hz

Installation type Installation with base plate		
Wet/dry use WET	Drilling variant	Flushing valve - drilling -
Discharge DN 80 EN 1092-2	Suction DN 100 UNDRILLED	Pressure rating (suction/discharge): -/PN 10
Accessory KBS 3F I220 (S)		Accessory code 9024.114
Note: Accessory must be ordered separately		

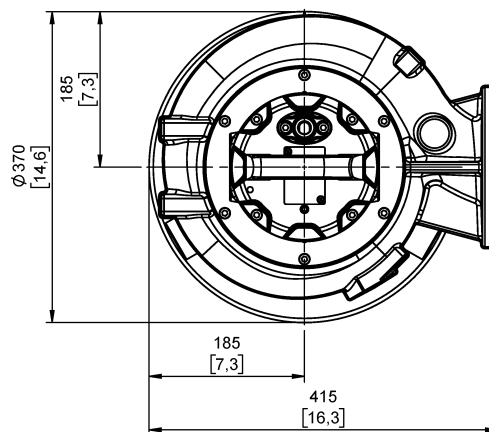
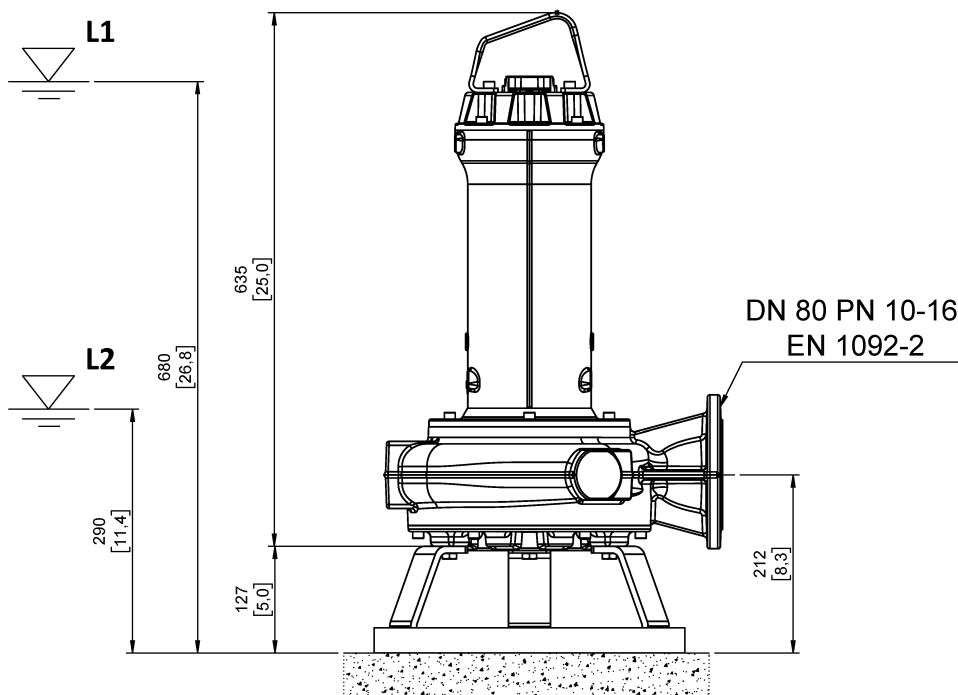

[mm
[inch]

L1: Minimum operating level for S1 - continuous use

L2: Minimum operating level for S3 - discontinuous use (excluding FM models)